

CIRCULAR MOTION
PROVINCIAL EXAMINATION ASSIGNMENT
ANSWER KEY / SCORING GUIDE

PART A: Multiple Choice (each question worth ONE mark)

Q	K	Q	K
1.	B	16.	A
2.	A	17.	A
3.	C	18.	C
4.	B	19.	D
5.	D	20.	B
6.	D	21.	B
7.	A	22.	D
8.	A	23.	A
9.	D	24.	C
10.	B	25.	C
11.	A	26.	B
12.	B	27.	A
13.	D	28.	C
14.	B	29.	C
15.	B	30.	C

1. The diagram shows a toy plane flying in a circle of radius 1.20 m, supported by a string which makes an angle of 28° with the vertical. The tension in the string is 1.80 N.

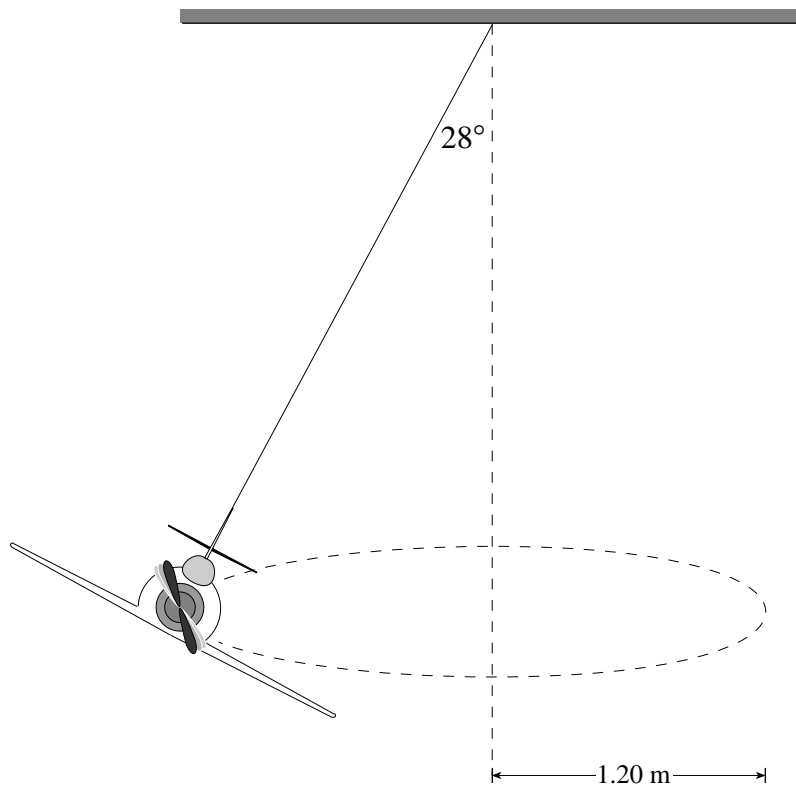

a) What is the mass of the plane?

(3 marks)

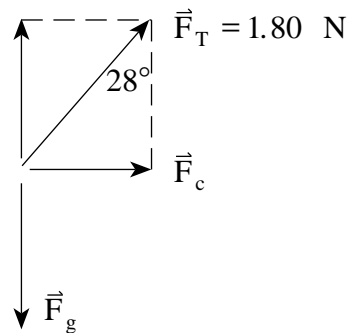

$$F_g = F_T \cos 28^\circ$$

$$= 1.59 \text{ N} \quad \leftarrow \text{2 marks}$$

$$m = \frac{1.59}{9.8} = 0.16 \text{ kg} \quad \leftarrow \text{1 mark}$$

b) How long does the plane take to complete one orbit?

(4 marks)

$$F_C = F_T \sin 28^\circ$$

$$= 0.845 \text{ N}$$

← 2 marks

$$\frac{m4\pi^2 r}{T^2} = 0.845$$

$$T = \sqrt{\frac{0.16 \times 4\pi^2 \times 1.20}{0.845}} = 3.00 \text{ s} \quad \leftarrow 2 \text{ marks}$$

2. A 35 kg child rides a ferris wheel of radius 12 m. The child moves in a vertical circle at a constant speed and completes one rotation every 9.0 s.

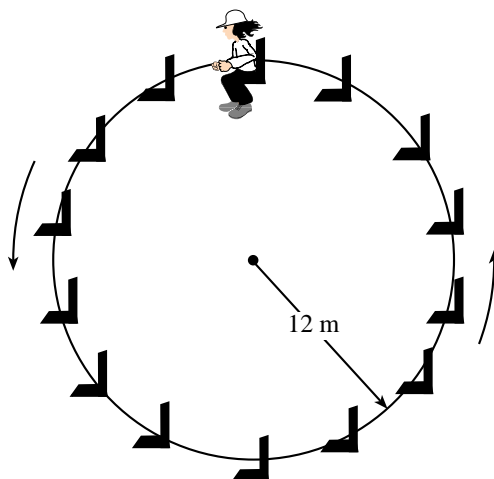

- a) As the child travels over the top, what is the magnitude of the force that the seat exerts on the child? **(5 marks)**

$$F_{\text{net}} = F_g - F_N$$

$$F_c = F_g - F_N \quad \leftarrow \text{2 marks}$$



$$F_N = F_g - F_c$$

$$= mg - \frac{m4\pi^2 r}{T^2}$$

$$= (35)(9.8) - \frac{(35)(4\pi^2)(12)}{(9.0)^2} \quad \leftarrow \text{2 marks}$$

$$= 343 - 205$$

$$F_N = 138 \text{ N} \quad \leftarrow \text{1 mark}$$

- b) How does the magnitude of the child's acceleration at the top of the ride compare to her acceleration at the bottom?

The child's acceleration at the top is: (circle one) **(1 mark)**

- i) less than at the bottom.
- ii) greater than at the bottom.
- iii) the same as at the bottom.**

Explain your choice using principles of physics. **(3 marks)**

Since this child is moving in uniform circular motion her net force must be a constant centripetal force. The magnitude of the acceleration must therefore be constant.

3. A 3.5 kg object is suspended by a string and moves in a horizontal circle of radius 0.60 m. The tension in the string is 36 N.

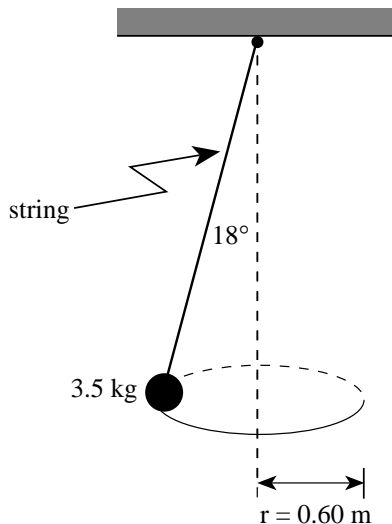

- a) What is the magnitude of the net force on the object?

(3 marks)

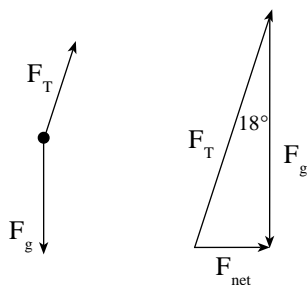

$$\sin 18^\circ = \frac{F_{net}}{F_T}$$

$$F_{net} = F_T \sin 18^\circ$$

$$= (36) \sin 18^\circ$$

$$F_{net} = 11 \text{ N} \quad \leftarrow \text{3 marks}$$

- b) What is the period of revolution of the object?

(4 marks)

$$F_{net} = \frac{m4\pi^2 r}{T^2} \quad \leftarrow \text{2 marks}$$

$$T^2 = \frac{m4\pi^2 r}{F_{net}} \quad \leftarrow \text{1 mark}$$

$$= \frac{(3.5)(4\pi^2)(0.60)}{11}$$

$$T = 2.7 \text{ s} \quad \leftarrow \text{1 mark}$$

4. A 6.1 kg object on the end of a massless connecting rod moves in uniform circular motion in a vertical circle with radius 1.2 m. The period of revolution is 0.80 s.

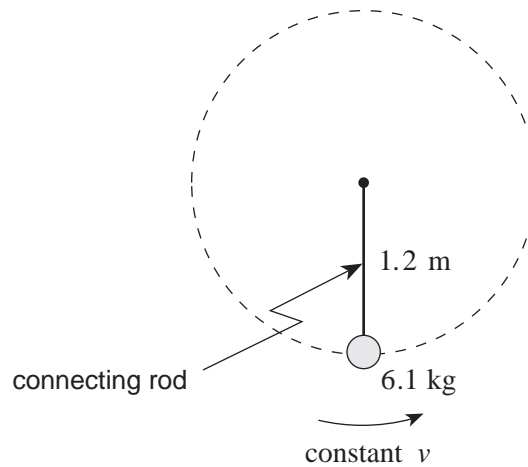

- a) Draw and label a free body diagram for the object at the bottom of the circular path. **(2 marks)**

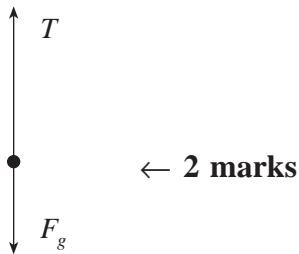

- b) Calculate the tension in the connecting rod at this position. **(5 marks)**

$$F_{net} = ma$$

$$T - F_g = m \left(\frac{4\pi^2}{T^2} r \right) \quad \left. \vphantom{\frac{4\pi^2}{T^2} r} \right\} \leftarrow 2 \text{ marks}$$

$$T - mg = m \frac{4\pi^2}{T^2} r$$

$$T - 6.1 \text{ kg} \cdot 9.8 \text{ m/s}^2 = \frac{6.1 \text{ kg} \cdot 4\pi^2 \cdot 1.2 \text{ m}}{(0.80 \text{ s})^2} \quad \left. \vphantom{\frac{6.1 \text{ kg} \cdot 4\pi^2 \cdot 1.2 \text{ m}}{(0.80 \text{ s})^2}} \right\} \leftarrow 2 \text{ marks}$$

$$T - 60 \text{ N} = 452 \text{ N}$$

$$T = 510 \text{ N} \quad \leftarrow 1 \text{ mark}$$

5. A space station of radius 90 m is rotating to simulate a gravitational field.

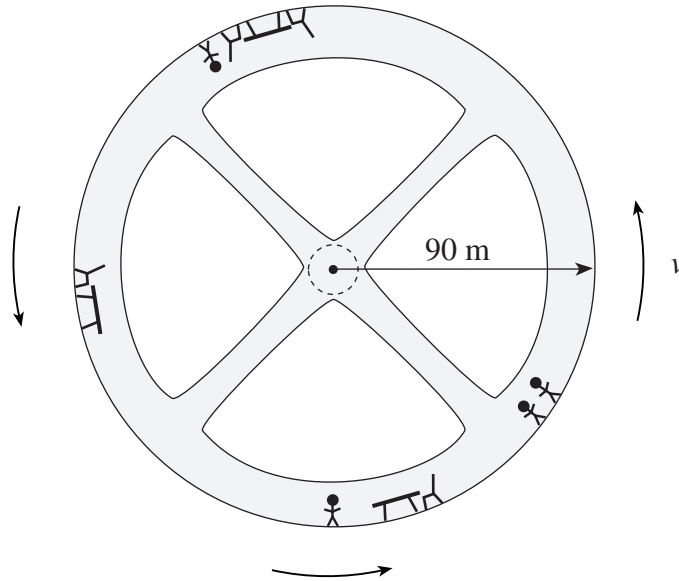

- a) What is the period of the space station's rotation so that a 70 kg astronaut will experience a normal force by the outer wall equal to 60% of his weight on the surface of the earth?

(5 marks)

$$F_{net} = ma_c \quad \leftarrow \text{1 mark}$$

$$0.60 mg = m \frac{4\pi^2}{T^2} R \quad \left. \vphantom{0.60 mg = m \frac{4\pi^2}{T^2} R} \right\} \leftarrow \text{3 marks}$$

$$T^2 = \frac{4\pi^2(90)}{0.60(9.8)}$$

$$T = 25 \text{ s} \quad \leftarrow \text{1 mark}$$

- b) What would be the effect experienced by the astronaut if the space station rotated faster so that the period of rotation was decreased? Explain your predicted effect. **(4 marks)**

The period is decreased and therefore the centripetal force increases ($F_c \propto \frac{1}{T^2}$). Since the centripetal force is only provided by the normal force, the normal force on the astronaut increases (F_N is perceived as weight.)

6. A 85 kg acrobat supported by a 6.0 m rope swings along a circular path from rest at position **X** as shown below. The rope hangs from the end of a uniform boom of mass 54 kg. Find the tension force as the acrobat passes the lowest point, position **Y**. **(9 marks)**

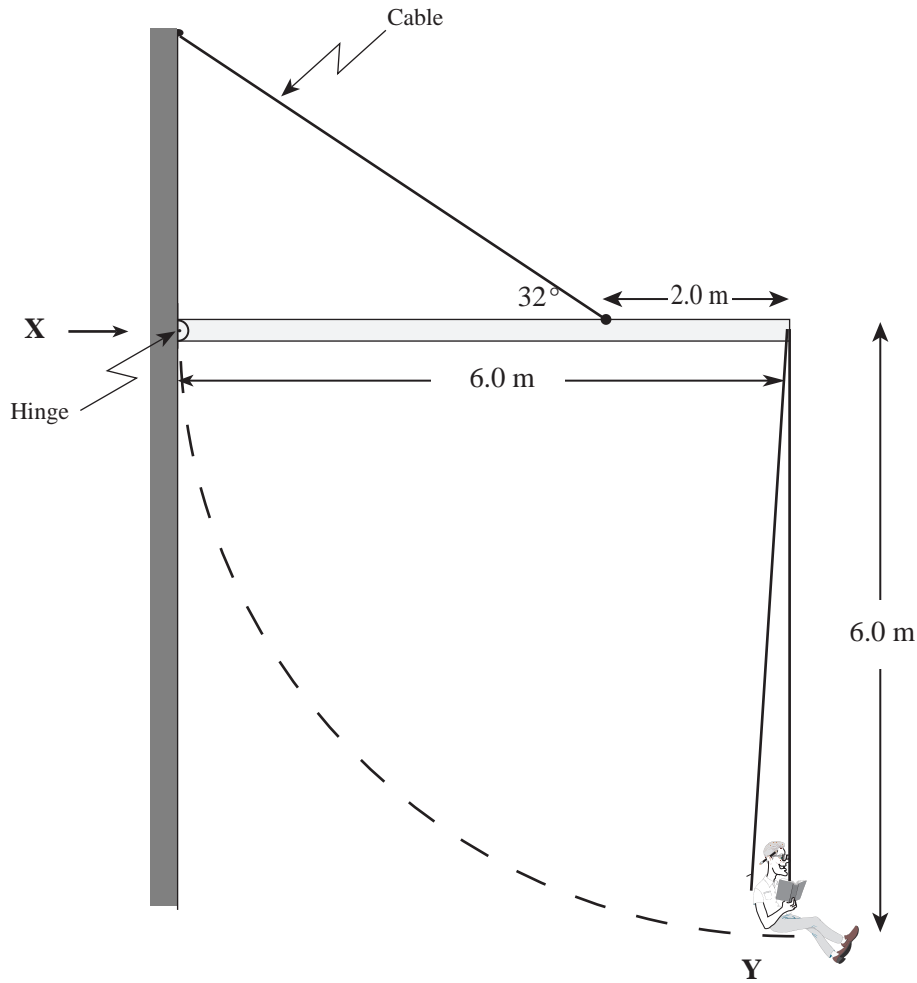

COE

$$mgh = \frac{1}{2}mv^2$$

$$v = \sqrt{2gh} = \sqrt{2(9.8)(6.0)} = 10.8 \frac{\text{m}}{\text{s}} \quad \text{2 marks}$$

FBD

$$T = F_g + F_c = mg + \frac{mv^2}{r}$$

$$T = m g + \frac{v^2}{r} = (85) 9.8 + \frac{10.8^2}{6.0} = 2500\text{N} \quad \text{3 marks}$$

FBD

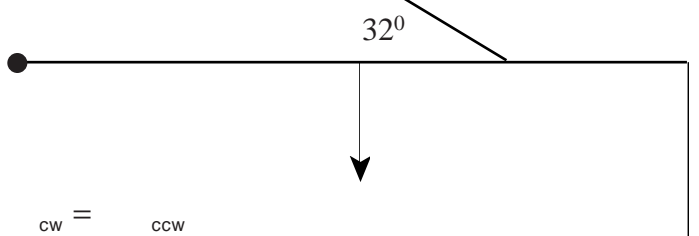

$$\begin{aligned} \text{cw} &= \text{ccw} \\ (T_{\text{rope}})(6.0) + (W_{\text{boom}})(3.0) &= (T_{\text{cable}})(\sin 32^\circ)(4.0) \\ (2500)(6.0) + (54)(9.8)(3.0) &= (T_{\text{cable}})(\sin 32^\circ)(4.0) \end{aligned} \quad \text{3 marks}$$

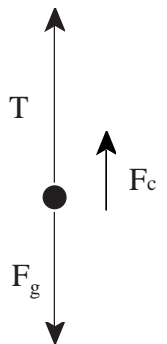

$$T_{\text{cable}} = 7.82 \cdot 10^3 \text{N} \quad \text{1 mark}$$

7. A racetrack surface has the shape of an inverted cone on which cars race in horizontal circles. For a steady speed of 29 m/s, to what distance d should a driver take her car, if she wishes to stay on a circular path without friction? **(9 marks)**

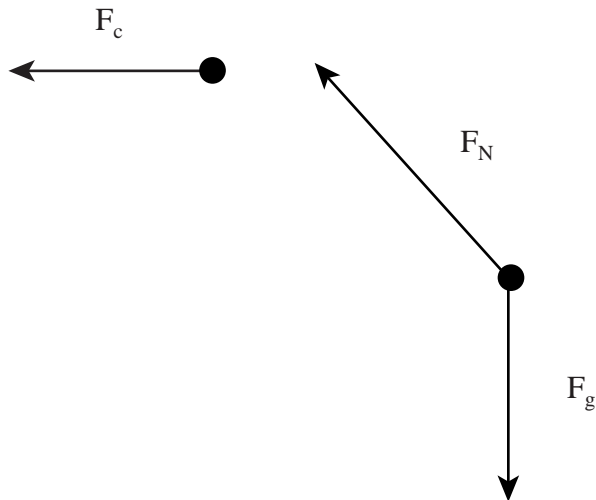
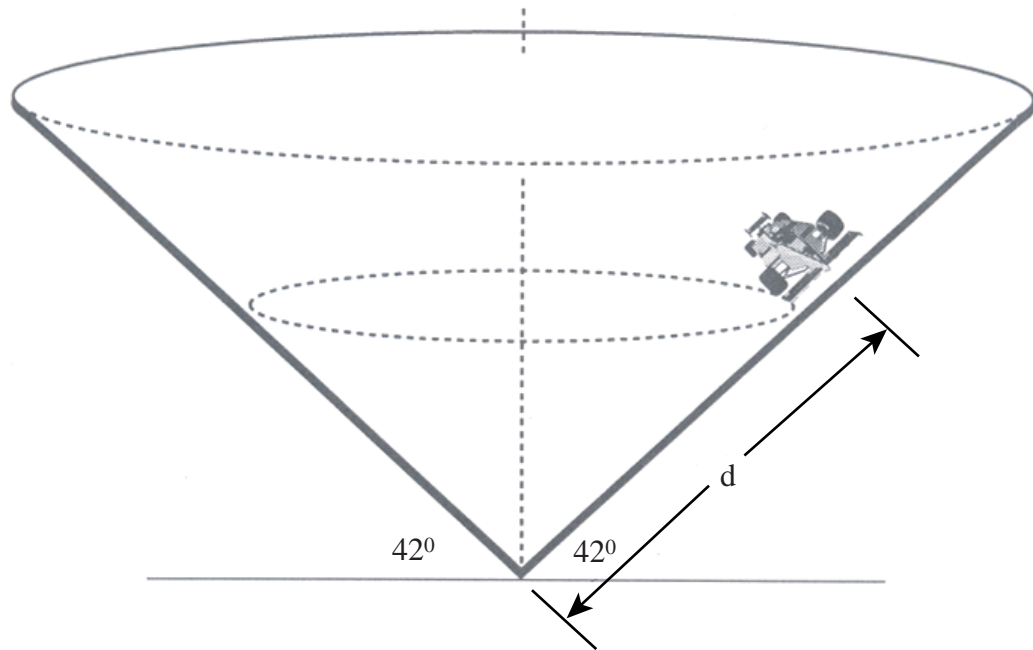

$$F_N \sin 48^\circ = F_g \quad 2 \text{ marks}$$

$$F_N \cos 48^\circ = F_C$$

$$\frac{F_N \sin 48^\circ}{F_N \cos 48^\circ} = \frac{F_g}{F_C} = \frac{mg}{\frac{mv^2}{r}} = \frac{rg}{v^2} \quad 3 \text{ marks}$$

$$\tan 48^\circ = \frac{(r)(9.8)}{29^2} \quad 2 \text{ marks}$$

$$r = 95\text{m}$$

$$\sin 48^\circ = \frac{r}{d} = \frac{95}{d} \quad 2 \text{ marks}$$

$$d = 130\text{m}$$

8. A mass is suspended by a string attached to a spring scale that initially reads 14 N as shown in Diagram 1.

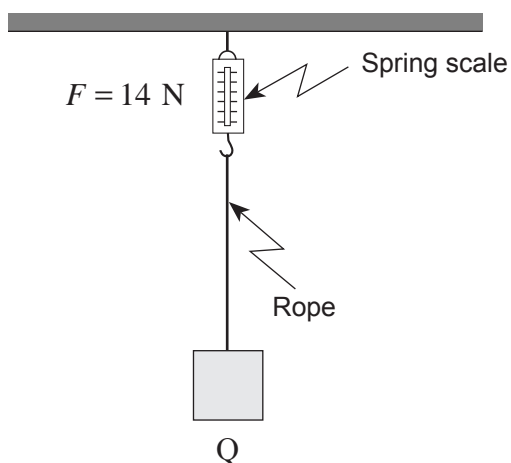

The mass is pulled to the side and then released as shown in Diagram 2.

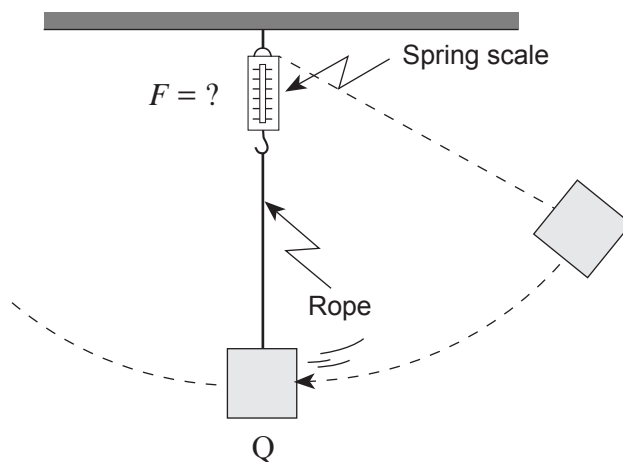

As the mass passes point Q, how will the reading on the spring scale compare to the previous value of 14 N? Using principles of physics, explain your answer. **(4 marks)**

The reading will be greater than 14 N. (by $\frac{mv^2}{r}$) ← 1 mark

Initially, the net force is zero, so the spring scale reads the weight of the mass. When moving, there is a net (centripetal) force provided by the spring scale (tension in the rope) which exceeds the weight (force of gravity) of the mass so that the mass goes in a vertical circle. ← 3 marks

9. During a roller coaster ride, the riders move through two loops, the second being one-half the radius of the first. The riders, however, travel at the same speed at the top of each of these two loops.

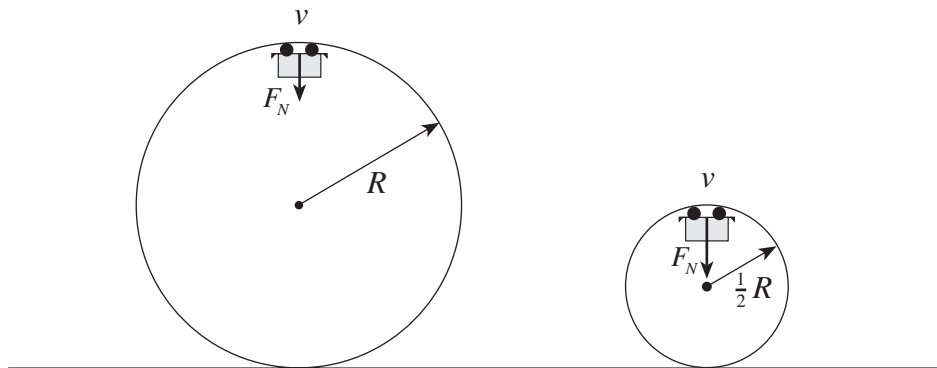

Using principles of physics, explain why the riders would experience a greater normal force at the top of the second smaller loop than at the top of the first larger loop. **(4 marks)**

The centripetal force is the sum of the normal force and the force of gravity on the riders

(1 mark). Since the radius decreases while the velocity does not change in the smaller loop

the centripetal force must increase $\left(F_c \propto \frac{1}{R}\right)$ (2 marks). The normal force must increase to

provide a greater centripetal force as force of gravity remains constant (1 mark).